

NO	QTY	PART NO	DESCRIPTION	STD SEAL KIT	FKM SEAL KIT
1	1	21500010	SCREW, CAP, BTNH, M12 X 20, ALY		
2	2	21500019	SCREW, CAP, BTNH, M3 X 6, ALY		
3	2	21500200	WASHER		
4	3	23600002	BALL, STEEL, ALLOY, .250	X	X
5	1	29740200	SENSOR, ULTRASONIC, M12, 1m		
6	1	39011030	SEAL,CROWN,1-1/16x1-1/4x5/32	X	39V11030
7	1	39011046	SEAL,BEVEL W/HEEL INSERT,7/8 x1/8 x1 1/8	X	39V11046
8	2	39050042	O-RING, (-011)	X	39051025
9	1	39053000	WIPER,SNAP-IN, (7/8)	X	X
10	1	43000040	O-RING, DIN3869, M18		43000041
11	2	43068006	PLUG, PORT, HOLLOW HEX, G1/4		
12	1	47510921	PLUNGER, SC, HS, 2600/11.6KN, RH, LS, US		
13	1	81400082	RETAINER, SC, HS, 2600, US		
14	3	90199958	ASSY,BALLSEAT,SC,2600/5000	X	X
15	1	39F54002	BU RING,(-212 CUSTOM)	X	X
16	1	39V51043	O-RING, (-918)	X	X
N/A	N/A	60414504	KIT, SEAL, STANDARD	INCLUDED IN KIT	
N/A	N/A	6V414504	KIT, SEAL, FKM		

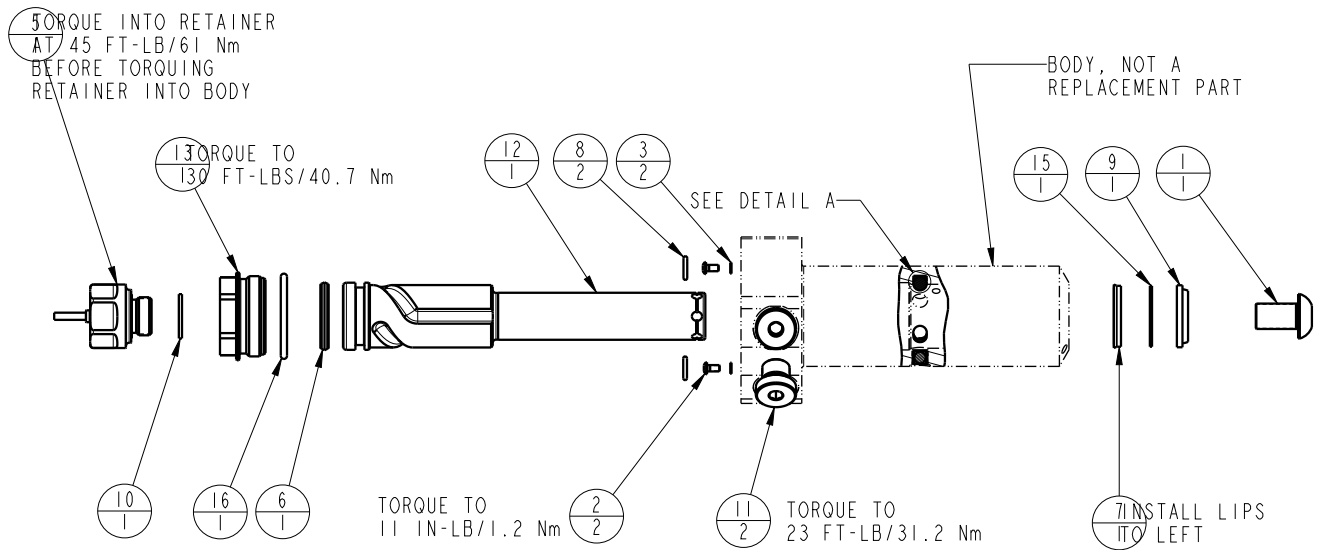

PARTS LIST	
	VEKTEK, INC. 1334 E. SIXTH AVE. P.O. BOX 625 EMPORIA, KS. 66801 U.S.A.
ASSEMBLIES AFFECTED 41421123US	PARTS LIST, ASSY, SC, BF, TC, 11.6KN, DA, RH, LS, US
SIZE A	MPL1455
	REV A

A	5660	RELEASE	ALS	3/24/25
REV	IN ACCORDANCE WITH ECN	EFFECTIVE DATE	REVISED BY	DATE
DRW BY:	ALS	DRAWING STATUS: Released PRODUCTION APPROVED FOR RELEASED STATUS ONLY		
DATE:	2/5/25			